

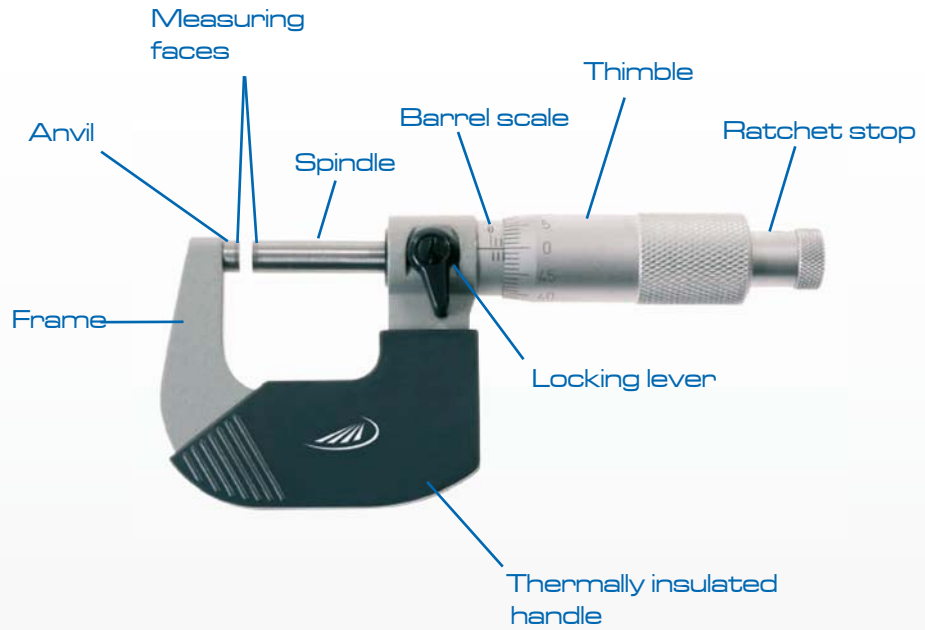

# SAMPLES MICROMETERS



**NEW**



## Micrometer highlights from our assortment



**INTERNAL MICROMETERS**



**SPECIAL MICROMETERS**



**HOLDER & SETTING STANDARDS**

## 2. CHAPTER MICROMETERS

86	External micrometers
93	Digital external micrometers
98	Precision dial micrometers
99	External micrometers with special measuring faces
101	Setting standards for micrometers
102	External micrometers for thread flank measurement
105	External micrometers for gear tooth measurements
106	Wire micrometer
107	Internal micrometers
111	Digital 2 point internal micrometers
114	Digital internal micrometers / with measuring pistol
118	Measuring heads and extensions
119	Depth micrometers



## 0800 External micrometers



**DIN**  
**863-1**

### Model

- DIN 863-1
- Reading: 0.01 mm
- Reading parts are satin chrome finished
- Locking lever
- Ratchet stop
- Carbide measuring faces
- Thermally insulated

### Delivery

- Plastic case
- From measuring range 25 - 50 mm upwards includes a setting standard

0800 501

✂	⚙	Measuring range mm	Pitch mm	Spindle dia. mm	Thimble dia. mm	Error limit mm	Order no.	List price EUR
		0 - 25	0.5	6.5	17	0.004	0800 501	18.10
		25 - 50	0.5	6.5	17	0.004	0800 502	22.00
		50 - 75	0.5	6.5	17	0.005	0800 503	25.20
		75 - 100	0.5	6.5	17	0.005	0800 504	29.80

## 0800 Set of external micrometers



### Delivery

- Includes 4 external micrometers
- Incl. setting gauges 25/50/75 mm
- Wooden case

**DIN**  
**863-1**

✂	⚙	Measuring range mm	Pitch mm	Spindle dia. mm	Thimble dia. mm	Order no.	List price EUR
		0 - 100	0.5	6.5	17	0800 513	106.00

## 0807 Holder for external micrometers



### Model

- With heavy cast iron base
- Vertically rotating and lockable

### Delivery

- Cardboard box

✂	⚙	Measuring range mm	Order no.	List price EUR
		0 - 300	0807 101	54.00



## 0806 External micrometers with friction clutch



**DIN**  
**863-1**



0806 501

### Model

- DIN 863-1
- Reading: 0.01 mm
- Reading parts are satin chrome finished
- Locking lever
- With friction clutch (ratchet)
- Fixed quick drive
- Carbide measuring faces
- Thermally insulated

### Delivery

- Plastic case
- From measuring range 25 - 50 mm upwards includes a setting gauge

⌘	⌘	Measuring range mm	Pitch mm	Spindle dia. mm	Thimble dia. mm	Error limit mm	Order no.	List price EUR
		0 - 25	0.5	6.5	18	0.004	0806 501	32.70
		25 - 50	0.5	6.5	18	0.004	0806 502	35.80
		50 - 75	0.5	6.5	18	0.005	0806 503	39.00
		75 - 100	0.5	6.5	18	0.005	0806 504	42.10

2

## 0806 Set of external micrometers with friction clutch



**DIN**  
**863-1**



0806 513

### Delivery

- Includes 4 external micrometers
- Incl. setting gauges 25/50/75 mm
- Wooden case

⌘	⌘	Measuring range mm	Pitch mm	Spindle dia. mm	Thimble dia. mm	Error limit mm	Order no.	List price EUR
		0 - 100	0.5	6.5	18	0.005	0806 513	154.00



## 0806 External micrometers



**DIN**  
**863-1**



### Model

- DIN 863-1
- Reading 0.01 mm
- Reading parts are satin chrome finished
- Locking lever
- Ratchet stop
- Carbide measuring faces
- Thermally insulated
- Coated steel frame

### Delivery

- Plastic case
- From measuring range 25 - 50 mm upwards includes a setting standard

✕	¼	Measuring range mm	Pitch mm	Spindle dia. mm	Thimble dia. mm	Error limit mm	Order no.	List price EUR
		0 - 25	0.5	6.5	17.5	0.004	0806 521	44.80
		25 - 50	0.5	6.5	17.5	0.004	0806 522	71.00
		50 - 75	0.5	6.5	17.5	0.005	0806 523	87.00
		75 - 100	0.5	6.5	17.5	0.005	0806 524	101.00
		100 - 125	0.5	6.5	17.5	0.006	0806 525	137.00
		125 - 150	0.5	6.5	17.5	0.006	0806 526	154.00
		150 - 175	0.5	6.5	17.5	0.007	0806 527	171.00
		175 - 200	0.5	6.5	17.5	0.007	0806 528	188.00

## 0806 Set of external micrometers



**DIN**  
**863-1**



### Delivery

- Includes 4 external micrometers
- Incl. setting gauges 25 + 75 mm or 125 + 175 mm
- Wooden case

✕	¼	Measuring range mm	Pitch mm	Spindle dia. mm	Thimble dia. mm	Order no.	List price EUR
		0 - 100	0.5	6.5	17.5	0806 540	264.00
		100 - 200	0.5	6.5	17.5	0806 542	581.00



**0810 External micrometers**



**DIN**  
**863-1**



0810 504

**Model**

- DIN 863-1
- Reading: 0.01 mm
- Reading parts are satin chrome finished
- Locking ring
- Spheroid ductile iron frame, lacquered
- Ratchet stop
- Carbide measuring faces
- Thermally insulated

**Delivery**

- Wooden case

2

⌘	⌘	Measuring range mm	Pitch mm	Spindle dia. mm	Thimble dia. mm	Error limit mm	Order no.	List price EUR
		0 - 25	1	8	30	0.004	0810 501	248.00
		25 - 50	1	8	30	0.004	0810 502	262.00
		50 - 75	1	8	30	0.005	0810 503	275.00
		75 - 100	1	8	30	0.005	0810 504	292.00

**0815 External micrometers with deep frame**



**DIN**  
**863-1**



0815 530

**Model**

- DIN 863-1
- Reading: 0.01 mm
- Reading parts are satin chrome finished
- Steel bracket lacquered
- Ratchet stop
- Carbide measuring faces
- Wooden case

**Delivery**

⌘	⌘	Measuring range mm	Frame depth mm	Pitch mm	Spindle dia. mm	Thimble dia. mm	Error limit mm	Order no.	List price EUR
		0 - 25	100	1	8	24	0.004	0815 510	261.00
		0 - 25	150	1	6.5	24	0.004	0815 514	275.00
		0 - 25	250	1	6.5	24	0.004	0815 518	344.00
		0 - 50	50	1	8	24	0.004	0815 530	296.00
		0 - 50	100	1	8	24	0.004	0815 534	437.00
		50 - 100	100	1	8	24	0.005	0815 540	483.00



## 0816 External micrometers large spindle distance 50 mm



**DIN  
863-1**



### Model

- DIN 863-1
- Direct reading 0.01 mm, without addition because of thread pitch 1 mm
- Reading parts are satin chrome finished

### Delivery

- Wooden case

- Locking ring
- Ratchet stop
- Carbide measuring faces
- Thermally insulated
- With 50 mm spindle movement and a wide measuring range
- Spheroid ductile iron frame. lacquered or coated light alloy frame

✕	⊘	Measuring range mm	Pitch mm	Spindle dia. mm	Thimble dia. mm	Error limit mm	Order no.	List price EUR
		0 - 50	1	8	24	0.004	0816 501	312.00
		50 - 100	1	8	24	0.005	0816 502	352.00
		100 - 150	1	8	24	0.006	0816 503	406.00
		150 - 200	1	8	24	0.007	0816 504	464.00
		200 - 250	1	8	24	0.008	0816 505	528.00
		250 - 300	1	8	24	0.009	0816 506	596.00
		300 - 350	1	10	24	0.01	0816 507	842.00
		350 - 400	1	10	24	0.011	0816 508	889.00
		400 - 450	1	10	24	0.012	0816 509	944.00
		450 - 500	1	10	24	0.013	0816 510	1013.00
		500 - 550	1	10	24	0.015	0816 511	1093.00
		550 - 600	1	10	24	0.017	0816 512	1170.00





## 0817 External micrometers with wide range of applications 100 mm



DIN  
863-3



2

### Model

- DIN 863-3
- Direct reading 0.01 mm, without addition because of thread pitch 1 mm
- Reading parts are satin chrome finished

- Spindle adjustment 50 mm
- Reversible anvil (screwed) for measuring range extension
- Locking ring

- Ratchet stop
- Carbide measuring faces
- Thermally insulated
- Robust coated light alloy frame

### Delivery

- Wooden case

»	¼	Measuring range mm	Pitch mm	Spindle dia. mm	Thimble dia. mm	Error limit mm	Order no.	List price EUR
		200 - 300	1	10	24	0.006	0817 512	1005.00
		300 - 400	1	10	24	0.007	0817 514	1045.00
		400 - 500	1	10	24	0.008	0817 516	1170.00
		500 - 600	1	10	24	0.009	0817 518	1327.00
		600 - 700	1	10	24	0.009	0817 520	1485.00
	▪	700 - 800	1	10	24	0.009	0817 522	1647.00
	▪	800 - 900	1	10	24	0.01	0817 524	1813.00
	▪	900 - 1000	1	10	24	0.01	0817 526	2006.00
	▪	1000 - 1100	1	10	24	0.011	0817 528	2209.00
	▪	1100 - 1200	1	10	24	0.011	0817 530	2417.00
	▪	1200 - 1300	1	10	24	0.012	0817 532	2645.00
	▪	1300 - 1400	1	10	24	0.012	0817 534	2931.00
	▪	1400 - 1500	1	10	24	0.013	0817 536	3128.00
	▪	1500 - 1600	1	10	24	0.018	0817 538	4898.00
	▪	1600 - 1700	1	10	24	0.019	0817 540	5198.00
	▪	1700 - 1800	1	10	24	0.02	0817 542	5593.00
	▪	1800 - 1900	1	10	24	0.021	0817 544	5925.00
	▪	1900 - 2000	1	10	24	0.022	0817 546	6295.00

## 0817 Replacement reversible anvil



### Model

- Exchangeable for all measuring ranges

»	¼	Length mm	Order no.	List price EUR
		50	0817 910	157.00





## 0819 External micrometers with interchangeable inserts

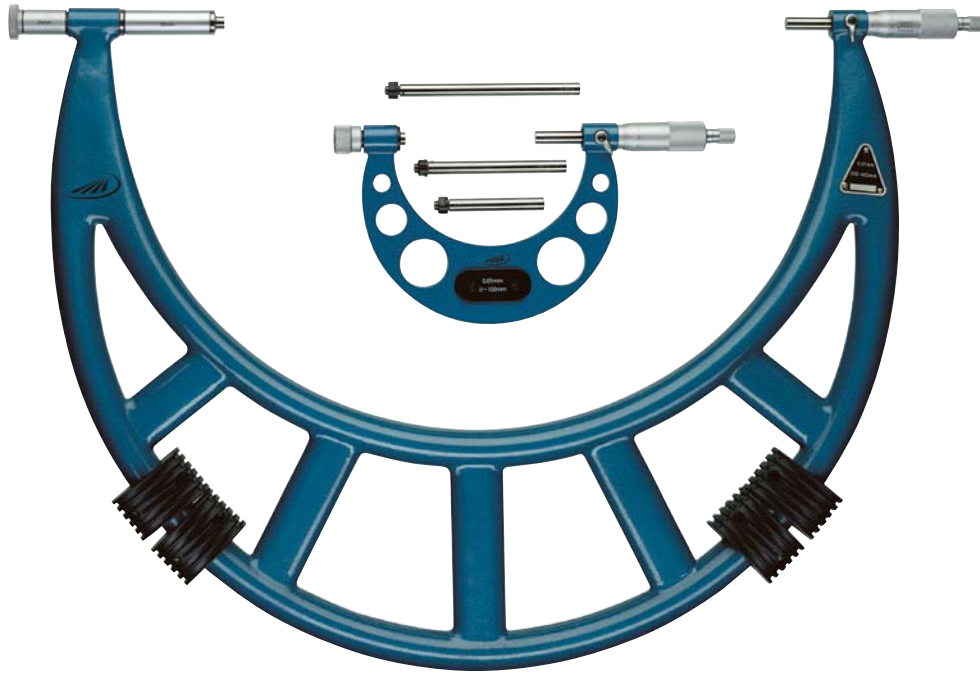

### Model

- Reading: 0.01 mm
- Reading parts are satin chrome finished
- Locking lever
- Ratchet stop
- Carbide measuring faces
- Thermally insulated
- Coated malleable cast iron frame\* or coated light alloy frame with interchangeable anvil

### Delivery

- Wooden case
- Includes setting standards

✕	¼	Measuring range mm	Pitch mm	Spindle dia. mm	Thimble dia. mm	Order no.	List price EUR
		0 - 100	0.5	8	20	0819 501	177.00
		0 - 150	0.5	8	20	0819 502	197.00
		100 - 200	0.5	8	20	0819 503	218.00
		150 - 300	0.5	8	20	0819 505	249.00
		200 - 300	0.5	8	20	0819 510	239.00
		300 - 400	0.5	8	24	0819 511	301.00
		400 - 500	0.5	8	24	0819 512	343.00
		500 - 600	0.5	8	24	0819 513	395.00
		600 - 700	0.5	8	24	0819 514	488.00
	▪	700 - 800	0.5	8	24	0819 515	561.00
	▪	800 - 900	0.5	8	24	0819 516	644.00
	▪	900 - 1000	0.5	8	24	0819 517	727.00
	▪	1000 - 1200	1	8	30	0819 519	1351.00
	▪	1200 - 1400	1	8	30	0819 521	1455.00
	▪	1400 - 1600	1	8	30	0819 523	1714.00
	▪	1600 - 1800	1	8	30	0819 525	1969.00
	▪	1800 - 2000	1	8	30	0819 527	2265.00



## 0912 Digital micrometers



### Model

- Protection class IP54
- Reading: 0.0001 mm / .00005 inch
- Locking lever
- Ratchet stop
- Carbide measuring faces
- Thermally insulated
- Factory standard

### Functions

- ON / OFF
- mm / inch switching
- Set to zero at any point

### Delivery

- Plastic case
- From measuring range 25 mm upwards includes a setting standard

Icon	Measuring range		Pitch	Spindle dia.	Error limit	Order no.	List price
	mm	inch					
	0 - 25	0 - 1	0.5	6.5	0.006	0912 501	78.00
	25 - 50	1 - 2	0.5	6.5	0.006	0912 502	88.00
	50 - 75	2 - 3	0.5	6.5	0.007	0912 503	101.00
	75 - 100	3 - 4	0.5	6.5	0.007	0912 504	115.00
	100 - 125	4 - 5	0.5	6.5	0.008	0912 505	127.00
	125 - 150	5 - 6	0.5	6.5	0.008	0912 506	139.00
	150 - 175	6 - 7	0.5	6.5	0.009	0912 507	150.00
	175 - 200	7 - 8	0.5	6.5	0.009	0912 508	161.00

Accessories	Order no.	List price
		EUR
Battery 1.5V, type 357	0220 204	3.20

## 0912 Set of digital micrometers



### Delivery

- Includes 4 micrometers
- Incl. setting gauges 25/50/75 mm
- Wooden case

Icon	Measuring range	Pitch	Spindle dia.	Order no.	List price
	mm	mm	mm		EUR
	0 - 100	0.5	6.5	0912 521	417.00



## 1866 Digital micrometers IP65



**NEW**

### Model

- Reading: 0.001 mm / .00005 inch
- Protection class IP65
- LCD display: 10 mm
- Rapid drive
- Carbide measuring faces
- Spindle stainless, hardened and smoothed
- Frame lacquered
- Thermally insulated
- Factory standard

### Functions

- ON / OFF
- **Quick-Start**
- **Quick-Lock** (key lock)
- Set to zero at any point
- mm / inch switching
- ABS (display can be set to zero without losing the Preset value)
- Hold
- ORIGIN (Preset value)
- TOL (tolerance value input)

### Delivery

- Plastic case
- from measuring range 25 mm upwards includes a setting standard

✂	Measuring range		Pitch	Spindle dia.	Thimble dia.	Error limit	Order no.	List price
	mm	inch						
	0 - 25	0 - 1	0.5	6.5	21	0.002	1866 410	199.00
	25 - 50	1 - 2	0.5	6.5	21	0.002	1866 413	259.00
	50 - 75	2 - 3	0.5	6.5	21	0.003	1866 417	329.00
	75 - 100	3 - 4	0.5	6.5	21	0.003	1866 420	375.00

### Accessories

Battery, 3V-Lithium, CR 2032

### Order no.

0220 704

### List price

EUR

3.70



HELIOS • PREISSER

1866i Digital micrometers IP65 with integrated wireless



**NOVELTY**  
Data transmission without cable  
or radio module

**integrated  
IW wireless**

2



186641 060

**Model**

- Reading: 0.001 mm / .00005 inch
- Protection class IP65
- LCD display: 10 mm
- Rapid drive
- Carbide measuring faces
- Spindle stainless, hardened and smoothed
- Frame lacquered
- Thermally insulated
- Factory standard

**Functions**

- ON / OFF
- **Quick-Start**
- **Quick-Lock** (key lock)
- Set to zero at any point
- mm / inch switching
- ABS (display can be set to zero without losing the Preset value)
- Hold
- ORIGIN (Preset value)
- TOL (tolerance value input)
- Integrated Wireless

**Delivery**

- Plastic case
- From measuring range 25 mm upwards includes a setting standard

Measuring range	Pitch		Spindle dia.	Thimble dia.	Error limit	Order no.	List price
	mm	inch					
0 - 25	0 - 1	0.5	6.5	21	0.002	186641 060	259.00
25 - 50	1 - 2	0.5	6.5	21	0.002	186641 360	319.00
50 - 75	2 - 3	0.5	6.5	21	0.003	186641 760	389.00
75 - 100	3 - 4	0.5	6.5	21	0.003	186642 060	435.00



1998780

**Accessories**

	Order no.	List price
		EUR
Battery, 3V-Lithium, CR 2032	0220 704	3.70
i-Stick USB-receiver for Integrated Wireless	1998 780	97.00

Integrated Wireless is intended to be sold in the EU only



# NEW

## 1866i Set of digital micrometers with integrated wireless



### Delivery

- Plastic case
- from measuring range 25 mm upwards includes a setting standard

Marked *	Measuring range		Pitch mm	Spindle dia. mm	Order no.	List price EUR
	mm	inch				
	0 - 100	0 - 4	0.5	6.5	186642 160	1390.00

## 1866 Digital micrometer BASIC



### Model

- Reading: 0.001 mm / .00005 inch
- Protection class IP40
- LCD display: 10 mm
- Rapid drive
- Carbide measuring faces
- Spindle stainless, hardened and smoothed
- Frame lacquered
- Thermally insulated
- Factory standard

### Functions

- ON / OFF
- **Quick-Start**
- **Quick-Lock** (key lock)
- Set to zero at any point
- mm / inch switching
- Hold

### Delivery

- Plastic case

Marked *	Measuring range		Pitch mm	Spindle dia. mm	Thimble dia. mm	Error limit mm	Order no.	List price EUR
	mm	inch						
	0 - 25	0 - 1	0.5	6.5	21	0.002	1866 210	169.00

### Accessories

Battery, 3V-Lithium, CR 2032

### Order no.

0220 704

### List price

EUR

3.70



## 0932 DIGI-MET® External micrometers



0932 701



0932 731

2

### Model

- Factory standard
- Selectable resolution 0.01 mm / 0.001 mm; 0.0005 inch / 0.00005 inch
- LCD display 6 mm
- Positive counting direction
- Non-rotating spindle
- Linear measuring system
- Locking lever\*
- Carbide measuring faces dia. 8 mm
- Thermally insulated
- Ratchet stop

### Functions

- ON / OFF
- Set to zero at any point
- mm / inch switching
- MIN / MAX
- TOL (tolerance value input)
- Hold
- PRESET-Function (setting a numerical value)
- Data output Opto RS 232

### Delivery

- Wooden case

» ¼	Measuring range		Pitch mm	Spindle dia. mm	Order no.	List price EUR
	mm	inch				
	0 - 25	0 - 1	1	8	0932 701	473.00
	25 - 50	1 - 2	1	8	0932 702	551.00
	50 - 75	2 - 3	1	8	0932 703	623.00
	75 - 100	3 - 4	1	8	0932 704	675.00
	100 - 125	4 - 5	1	8	0932 705	727.00
	125 - 150	5 - 6	1	8	0932 706	779.00
	150 - 175	6 - 7	1	8	0932 707	831.00
	175 - 200	7 - 8	1	8	0932 708	935.00
<b>With lifter - retraction stroke 1.5 mm (without locking lever*)</b>						
	0 - 25	0 - 1	1	8	0932 731	603.00
	25 - 50	1 - 2	1	8	0932 732	623.00
	50 - 75	2 - 3	1	8	0932 733	675.00
	75 - 100	3 - 4	1	8	0932 734	727.00



0996701

### Accessories

	Order no.	List price EUR
Battery, 3V-Lithium, CR 2032	0220 704	3.70
Data cable opto to RS232	0996 701	74.00
Data cable opto to USB	0996 705	141.00
USB-keyboard interface cable	0997 770	241.00



## 0849 Precision dial micrometers



DIN  
863-3



0849 501

### Model

- DIN 863-3
- Reading: 0.01 mm
- Reading on the dial: 1  $\mu\text{m}$
- Reading parts are satin chrome finished
- Retraction stroke 1.5 mm

- Spindle made of hardened stainless steel
- Constant measuring force
- Locking lever
- Carbide measuring faces
- Thermally insulated

### Delivery

- Wooden case

$\nabla$	$\frac{1}{2}$	Measuring range mm	Pitch mm	Spindle dia. mm	Thimble dia. mm	Order no.	List price EUR
		0 - 25	0.5	7.5	17.5	0849 501	707.00
		25 - 50	0.5	7.5	17.5	0849 502	841.00

## 0850 Precision dial micrometers



DIN  
863-3



0850 511

### Model

- DIN 863-3
- Reading: 0.01 mm
- Reading on the dial: 1  $\mu\text{m}$
- Reading parts are satin Chrome finished
- Retraction stroke 1.2 mm

- Locking lever
- Carbide measuring faces
- Constant measuring force
- Thermally insulated
- Spindle made of hardened Stainless steel

- Adjustable tolerance markers

### Delivery

- Wooden case
- incl. dial comparator gauge

$\nabla$	$\frac{1}{2}$	Measuring range mm	Pitch mm	Spindle dia. mm	Thimble dia. mm	Order no.	List price EUR
		0 - 25	0.5	7.5	17.5	0850 511	559.00
		25 - 50	0.5	7.5	17.5	0850 512	620.00
		50 - 100	0.5	7.5	17.5	0850 514	659.00
		100 - 150	0.5	7.5	17.5	0850 516	704.00
		150 - 200	0.5	7.5	17.5	0850 518	737.00





0822 Disc micrometers



**Model**

- Factory standard
- Reading: 0.01 mm
- Carbide measuring faces
- Ratchet stop
- Disc dia. 60 mm
- Malleable cast iron frame, lacquered

**Delivery**

- Wooden case

2

Measuring range mm	Pitch mm	Spindle dia. mm	Thimble dia. mm	Order no.	List price EUR
<b>Frame depth 50 mm</b>					
0 - 15	1	6.5	20	0822 301	91.00
0 - 25	1	6.5	20	0822 302	138.00
0 - 50	1	6.5	20	0822 303	254.00
<b>Frame depth 100 mm</b>					
0 - 50	1	6.5	20	0822 304	416.00

0824 Micrometers for tube wall measurement



DIN 863-3

**Model**

- DIN 863-3
- Reading: 0.01 mm
- Reading parts are satin chrome finished
- Ratchet stop
- Hardened measuring faces

- Malleable cast iron frame, lacquered

**Delivery**

- Cardboard box

Measuring range mm	Pitch mm	Spindle dia. mm	Thimble dia. mm	Error limit mm	Order no.	List price EUR
<b>Ball dia. 2.5 mm</b>						
0 - 15	0.5	6.5	20	0.001	0824 302	174.00
<b>Ball dia. 6.5 mm</b>						
0 - 25	0.5	6.5	20	0.001	0824 303	176.00



## 0854 Blade micrometers



**DIN**  
**863-3**



### Model

- DIN 863-3
- Reading: 0.01 mm
- Reading parts are satin chrome finished
- Ratchet stop
- Thermally insulated
- Hardened spindle and anvil
- Coated steel frame

### Delivery

- Plastic case
- From measuring range 25 - 50 mm upwards includes a setting standard

✂	¼	Measuring range mm	Pitch mm	Spindle dia. mm	Thimble dia. mm	Error limit mm	Order no.	List price EUR
<b>Measuring faces dia. 0.8 x 7 mm</b>								
		0 - 25	0.5	8	17.5	0.004	0854 301	247.00
		25 - 50	0.5	8	17.5	0.004	0854 302	299.00
		50 - 75	0.5	8	17.5	0.005	0854 303	321.00
		75 - 100	0.5	8	17.5	0.005	0854 304	348.00

## 0855 Micrometers with reduced measuring faces



**DIN**  
**863-3**



### Model

- DIN 863-3
- Reading: 0.01 mm
- Reading parts are satin chrome finished
- Locking lever
- Ratchet stop
- Carbide measuring faces
- Thermally insulated
- Hardened spindle and anvil
- Coated steel frame

### Delivery

- Plastic case
- From measuring range 25 - 50 mm upwards includes a setting standard

✂	¼	Measuring range mm	Pitch mm	Spindle dia. mm	Thimble dia. mm	Error limit mm	Order no.	List price EUR
<b>Measuring faces dia. 3 mm, length 8.5 mm</b>								
		0 - 25	0.5	6.5	17.5	0.004	0855 301	178.00
		25 - 50	0.5	6.5	17.5	0.004	0855 302	218.00
		50 - 75	0.5	6.5	17.5	0.005	0855 303	247.00
		75 - 100	0.5	6.5	17.5	0.005	0855 304	261.00



## 0898 Settings gauges for micrometers



0898 104

### Model

- Rod
- Special steel, aged
- Hardened measuring faces
- Tolerance zone js2
- Thermally insulated
- Parallel lapped measuring faces

⊗	⊗	Measuring range mm	Measuring faces dia. mm	Order no.	List price EUR
		25	6.5	0898 101	10.90
		50	6.5	0898 102	18.30
		75	6.5	0898 103	21.70
		100	6.5	0898 104	24.80
		125	6.5	0898 105	28.70
		150	6.5	0898 106	40.60
		175	6.5	0898 107	45.40
		200	6.5	0898 108	50.00
		225	6.5	0898 109	55.00
		250	6.5	0898 110	60.00
		275	6.5	0898 111	64.00
		300	10	0898 112	80.00
		325	10	0898 113	86.00
		350	10	0898 114	92.00
		375	10	0898 115	98.00
		400	10	0898 116	105.00
		425	10	0898 117	111.00
		450	10	0898 118	117.00
		475	10	0898 119	123.00
		500	10	0898 120	130.00
		525	10	0898 121	136.00
		550	10	0898 122	143.00
		575	10	0898 123	150.00
		600	10	0898 124	157.00
		625	10	0898 125	164.00
		650	10	0898 126	170.00

⊗	⊗	Measuring range mm	Measuring faces dia. mm	Order no.	List price EUR
		675	10	0898 127	177.00
		700	10	0898 128	184.00
		725	10	0898 129	191.00
		750	10	0898 130	198.00
		775	10	0898 131	205.00
		800	10	0898 132	212.00
		825	10	0898 133	217.00
		850	10	0898 134	224.00
		875	10	0898 135	232.00
		900	10	0898 136	239.00
		925	10	0898 137	245.00
		950	10	0898 138	252.00
		975	10	0898 139	260.00
		1000	10	0898 140	266.00
	▪	1050	10	0898 142	278.00
	▪	1150	10	0898 146	305.00
	▪	1250	10	0898 150	335.00
	▪	1350	10	0898 154	361.00
	▪	1450	10	0898 158	389.00
	▪	1550	10	0898 162	623.00
	▪	1650	10	0898 166	654.00
	▪	1750	10	0898 170	684.00
	▪	1850	10	0898 174	714.00
	▪	1950	10	0898 178	743.00



## 0870 Precision micrometers for thread flank measurement



DIN  
863-3



### Model

- DIN 863-3
- Reading 0.01 mm
- Reading parts are satin chrome finished
- Locking ring
- Ratchet stop
- Thermally insulated
- Spheroid ductile iron frame, lacquered

### Delivery

- Wooden case
- **Thread flank inserts and setting standards must be ordered separately**

✕	📏	Measuring range	Pitch	Thimble dia.	Error limit	Spindle adjustment	Required length of setting standard	Order no.	List price
		mm	mm	mm	mm	mm	mm		EUR
<b>For inserts with shank dimensions. dia. 3.5 x 13.5 mm</b>									
		0 - 25	0.5	20	0.004	25	-	0870 301	295.00
		25 - 50	0.5	20	0.004	25	25	0870 302	308.00
		50 - 75	0.5	20	0.005	25	50	0870 303	331.00
		75 - 100	0.5	20	0.005	25	75	0870 304	362.00
		100 - 125	0.5	20	0.006	25	100	0870 305	396.00
		125 - 150	0.5	20	0.006	25	125	0870 306	431.00
		150 - 200	0.5	20	0.007	50	175	0870 307	614.00
		200 - 250	0.5	20	0.008	50	225	0870 309	671.00
		250 - 300	0.5	20	0.009	50	275	0870 311	738.00



## 0870 Thread flank inserts for external measurement

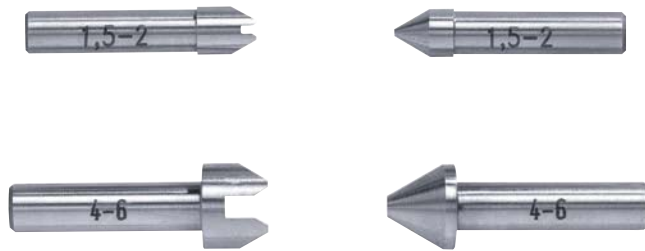

### Model

- Made of hardened special steel and finely grinded
- Every insert is inscribed with the pitch details
- In a set (V-anvil + tapered anvil)
- Shank dimensions: 3.5 x 13.5 mm

⏪	🏠	Flank angle	Pitch mm	Applicable for UNC, UNF 60°	Thread pitch in TPI mm	Order no.	List price EUR
<b>Metric ISO - threads</b>							
		60°	0.35 - 0.5	72 - 48		0870 901	111.00
		60°	0.6 - 0.8	44 - 32		0870 903	96.00
		60°	0.9 - 1.25	28 - 18		0870 905	96.00
		60°	1.5 - 2	16 - 11		0870 907	96.00
		60°	2.5 - 3.5	10 - 7		0870 909	96.00
		60°	4 - 6	6 - 4		0870 911	111.00
<b>Whitworth- threads</b>							
		55°			60 - 48	0870 921	121.00
		55°			40 - 32	0870 923	105.00
		55°			28 - 22	0870 925	105.00
		55°			20 - 16	0870 927	105.00
		55°			14 - 11	0870 929	105.00
		55°			10 - 7	0870 931	105.00
		55°			6 - 4	0870 933	121.00
<b>Metric ISO - Trapezoid threads (DIN 103)</b>							
		30°	1.5			0870 941	285.00
		30°	2			0870 943	207.00
		30°	3			0870 945	182.00
		30°	4			0870 947	182.00
		30°	5-6			0870 949	182.00
		30°	7-8			0870 951	182.00
		30°	9-10			0870 953	207.00
		30°	12-14			0870 955	285.00



## 0870 Thread flank setting gauges for external measurement



### Model

- Measuring faces made of hardened special steel
- One end is rounded, the lapped bore simplifies the fitting upon the conical insert
- Thermally insulated handle
- **Note: With trapezoid treads every pitch requires a separate setting standard**

⊗	⚙	Length mm	Flank angle	Available for following pitches mm	Error limit μm	Order no.	List price EUR
<b>Metric ISO - threads</b>							
		25	60°		3	0870 801	70.00
		50	60°		3	0870 802	71.00
		75	60°		3	0870 803	72.00
		100	60°		4	0870 804	73.00
		125	60°		4	0870 805	74.00
		175	60°		4	0870 807	82.00
		225	60°		4	0870 809	92.00
		275	60°		4	0870 811	102.00
<b>Whitworth- threads</b>							
		25	55°		3	0870 821	70.00
		50	55°		3	0870 822	71.00
		75	55°		3	0870 823	72.00
		100	55°		4	0870 824	77.00
		125	55°		4	0870 825	78.00
		175	55°		4	0870 827	89.00
		225	55°		4	0870 829	103.00
		275	55°		4	0870 831	117.00
<b>Metric ISO - Trapezoid threads (DIN 103)</b>							
		25	30°	2 / 3 / 4 / 5 - 6 / 7 - 8 / 9 - 10	4	0870 841	153.00
		50	30°	2 / 3 / 4 / 5 - 6 / 7 - 8 / 9 - 10	4	0870 842	157.00
		75	30°	2 / 3 / 4 / 5 - 6 / 7 - 8 / 9 - 10	4	0870 843	161.00
		100	30°	3 / 4 / 5 - 6 / 7 - 8 / 9 - 10 / 12 - 14	5	0870 844	168.00
		125	30°	4 / 5 - 6 / 7 - 8 / 9 - 10 / 12 - 14	5	0870 845	182.00
		175	30°	4 / 5 - 6 / 7 - 8 / 9 - 10 / 12 - 14	5	0870 847	217.00
		225	30°	5 - 6 / 7 - 8 / 9 - 10 / 12 - 14	5	0870 849	265.00
		275	30°	5 - 6 / 7 - 8 / 9 - 10 / 12 - 14	5	0870 851	324.00

\* When ordering the respective pitch must be specified



## 0864 Disc micrometers to measure gear tooth



**DIN**  
**863-3**

### Model

- DIN 863-3
- Reading: 0.01 mm
- Reading parts are satin chrome finished
- Modul 0.8 - 6
- Ratchet stop
- Hardened measuring faces
- Locking ring
- Friction coupling
- Thermally insulated

### Delivery

- Wooden case

⌘	⌘	Measuring range mm	Disc dia. mm	Pitch mm	Thimble dia. mm	Error limit mm	Order no.	List price EUR
		0 - 25	25	0.5	20	0.004	0864 321	317.00
		25 - 50	25	0.5	20	0.004	0864 322	380.00
		50 - 75	25	0.5	20	0.005	0864 323	412.00
		75 - 100	25	0.5	20	0.005	0864 324	447.00
		100 - 125	25	0.5	20	0.006	0864 325	483.00
		125 - 150	25	0.5	20	0.006	0864 326	517.00
		150 - 175	25	0.5	20	0.007	0864 327	556.00
		175 - 200	25	0.5	20	0.007	0864 328	594.00

## 0933 DIGI-MET® Disc micrometers to measure gear tooth



**OPTO**

### Model

- Factory standard
- Selectable resolution 0.01 mm / 0.001 mm; 0.0005 inch / 0.00005 inch
- Non-rotating spindle
- Linear measuring system
- Locking lever
- Thermally insulated
- Ratchet stop

### Functions

- ON / OFF
- Set to zero at any point
- mm / inch switching
- MIN / MAX
- Hold
- PRESET-Function (setting a numerical value)
- TOL (tolerance value input)
- Data output Opto RS 232

### Delivery

- Wooden case

⌘	⌘	Measuring range		Disc dia.	Module	Pitch	Spindle dia.	Order no.	List price
		mm	inch	mm		mm	mm		EUR
		0 - 25	0 - 1	25	0.4	1	8	0933 701	779.00
		25 - 50	1 - 2	25	0.4	1	8	0933 702	857.00
		50 - 75	2 - 3	25	0.4	1	8	0933 703	909.00
		75 - 100	3 - 4	25	0.4	1	8	0933 704	961.00
		100 - 125	4 - 5	30	0.6	1	8	0933 705	1013.00
		125 - 150	5 - 6	30	0.6	1	8	0933 706	1065.00
		150 - 175	6 - 7	30	0.6	1	8	0933 707	1117.00
		175 - 200	7 - 8	30	0.6	1	8	0933 708	1195.00



### Accessories

	Order no.	List price EUR
Battery, 3V-Lithium, CR 2032	0220 704	3.70
Data cable opto to RS232	0996 701	74.00
Data cable opto to USB	0996 705	141.00
USB-keyboard interface cable	0997 770	241.00





## 0890 Wire thickness micrometer



### Model

- Factory standard
- Reading: 0.01 mm
- Readings parts are satin chrome finished
- Ratchet stop
- Carbide measuring faces

### Delivery

- Cardboard box

⌘	⌘	Measuring range mm	Pitch mm	Spindle dia. mm	Thimble dia. mm	Order no.	List price EUR
		0 - 10	0.5	6	18	0890 511	66.00



**0884 Internal micrometer with measuring jaws**

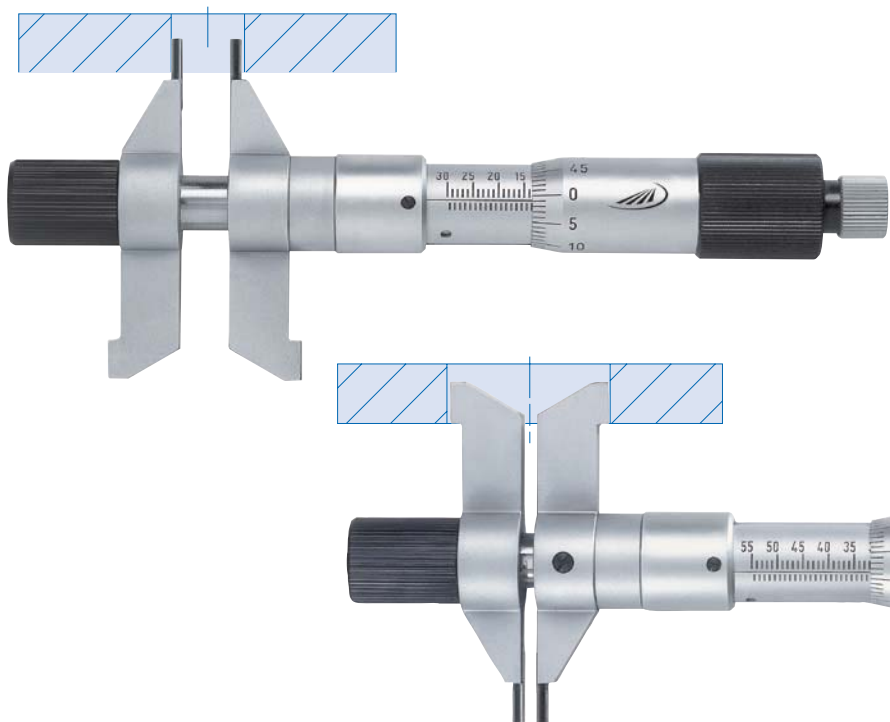

**Model**

**DIN  
863-4**

- DIN 863-4
- Reading: 0.01 mm
- Reading parts are satin chrome finished
- Forward friction coupling
- Cylindrical carbide tipped measuring faces
- Measuring jaws on both sides (measuring ranges 5-30 mm, 30-55 mm)
- Divisions on both sides

**Delivery**

- Wooden case

⌘	⌘	Measuring range mm	Thimble dia. mm	Pitch mm	Error limit µm	Order no.	List price EUR
		5 - 55	20	0.5	2.5	0884 501	794.00

2

**0885 Internal micrometers with measuring jaws**



0885 502

**Model**

- Factory standard
- Reading: 0.01 mm
- Reading parts and body are satin chrome finished
- Ratchet stop
- Carbide measuring faces
- Cylindrical carbide tipped measuring faces

**Delivery**

- Plastic case

⌘	⌘	Measuring range mm	Thimble dia. mm	Pitch mm	Order no.	List price EUR
		5 - 30	17	0.5	0885 501	176.00
		25 - 50	17	0.5	0885 502	195.00
		50 - 75	17	0.5	0885 503	204.00
		75 - 100	17	0.5	0885 504	245.00
		100 - 125	17	0.5	0885 505	311.00
		125 - 150	17	0.5	0885 506	359.00
		150 - 175	17	0.5	0885 507	457.00
		175 - 200	17	0.5	0885 508	518.00



## 0888 Internal micrometers cylindrical version



**DIN  
863-4**



### Model

- DIN 863-4
- Reading: 0.01 mm
- Reading parts are satin chrome finished
- Carbide measuring faces dia. 6 mm, spherical lapped
- From measuring range 100 - 125 mm with thermal insulation

- From measuring range 100 - 125 mm with locking ring

### Delivery

- Wooden case

✕	¼	Measuring range mm	Thimble dia. mm	Pitch mm	Error limit µm	Order no.	List price EUR
		25 - 30	15	0.5	4	0888 501	154.00
		30 - 35	15	0.5	4	0888 502	154.00
		35 - 50	15	0.5	4	0888 503	154.00
		50 - 75	16	0.5	5	0888 504	160.00
		75 - 100	17	0.5	5	0888 505	166.00
		100 - 125	20	0.5	6	0888 506	185.00
		125 - 150	20	0.5	6	0888 507	190.00
		150 - 175	20	0.5	7	0888 508	197.00
		175 - 200	20	0.5	7	0888 509	204.00
		200 - 225	20	0.5	8	0888 510	210.00
		225 - 250	20	0.5	8	0888 511	216.00
		250 - 275	20	0.5	9	0888 512	224.00
		275 - 300	20	0.5	9	0888 513	232.00
		300 - 325	20	0.5	10	0888 514	241.00
		325 - 350	20	0.5	10	0888 515	247.00
		350 - 375	20	0.5	11	0888 516	257.00
		375 - 400	20	0.5	11	0888 517	263.00
		400 - 425	20	0.5	12	0888 518	273.00
		425 - 450	20	0.5	12	0888 519	281.00
		450 - 475	20	0.5	13	0888 520	288.00
		475 - 500	20	0.5	13	0888 521	295.00

## 0888 Holder for internal micrometers

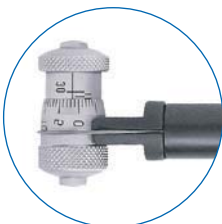

### Model

- Ideal for all internal micrometers from series 0888 / 0892
- Length 200 mm

✕	¼	Order no.	List price EUR
		0888 101	49.00



## 0892 Internal micrometers with interchangeable extensions



DIN 863-4

0892 501

### Model

- DIN 863-4
- Reading: 0.01 mm
- Reading parts are satin chrome finished

### Delivery

- Threaded extension rods with thermally insulated handle
- Carbide measuring faces, spherical lapped
- Wooden case

⌂	⚙	Measuring range mm	Thimble dia. mm	Pitch mm	Extensions	Error limit µm	Order no.	List price EUR
		50 - 150	17	0.5	25 / 50	6	0892 501	376.00
		50 - 250	17	0.5	25 / 50 / 100	8	0892 502	461.00
		50 - 450	17	0.5	25 / 50 / 100 / 200	10	0892 503	568.00
		50 - 850	17	0.5	25 / 50 / 100 / 200 / 400	12	0892 504	716.00
		50 - 1450	17	0.5	25 / 50 / 100 / 200 / 400 / 600	15	0892 505	909.00

## 0892 Extensions for internal micrometers



0892 334

⌂	⚙	Length mm	Order no.	List price EUR
		25	0892 332	71.00
		50	0892 333	72.00
		100	0892 334	80.00
		200	0892 336	98.00
		400	0892 339	130.00
		600	0892 340	182.00



## 0894 Precision internal micrometers with extensions



**DIN  
863-4**



### Model

- DIN 863-4
- Measuring ends: dia. 7 mm x 6 mm long, carbide tipped spherical lapped
- Thread pitch 1 mm
- Internal spring mounted rods with thermal protective sleeves
- Extensions greater than 100 mm: external steel tube dia. 17 mm, with thermal insulation
- Extensions 500 and 1000 mm: strengthened specification - steel tube dia. 32 mm for larger measuring ranges

### Delivery

- Wooden case

- Basic internal micrometer is adjustable: 50 mm. The spindle is tight, so that during measurement the thimble does not adjust itself.

✕	⊘	Measuring range mm	Length of extensions mm (tube dia. 17 mm)	Length of extensions (tube dia. 32 mm)	Error limit μm	Order no.	List price EUR
		100 - 150	only micrometer, excludes case	-	4	0894 504	224.00
		100 - 300	50 / 100	-	7	0894 510	595.00
		100 - 500	50 / 100 / 200	-	9	0894 514	802.00
		100 - 900	50 / 100 / 200 / 400	-	11	0894 518	1036.00
		100 - 1300	50 / 100 / 200 / 400 / 400	-	13	0894 522	1276.00
		100 - 1700	50 / 100 / 200 / 400 / 800	-	15	0894 526	1313.00
		100 - 2100	50 / 100 / 200 / 400 / 400 / 800	-	18	0894 530	1540.00
		100 - 2500	50 / 100 / 200 / 400 / 800 / 800	-	21	0894 534	1582.00
		100 - 2000	50 / 100 / 200 / 200	500 / 1 x 1000	18	0894 538	2761.00
		100 - 3000	50 / 100 / 200 / 200	500 / 2 x 1000	30	0894 542	3601.00
		100 - 4000	50 / 100 / 200 / 200	500 / 3 x 1000	40	0894 546	4470.00
	▪	100 - 5000	50 / 100 / 200 / 200	500 / 4 x 1000	50	0894 550	5311.00
	▪	100 - 6000	50 / 100 / 200 / 200	500 / 5 x 1000	60	0894 554	6152.00

With the larger measuring ranges we recommend that the ends of the precision internal micrometer to be placed and/or held on 2 points with an approximate distance of 22% of the measuring length, thus minimizing deflection. The error indicated in the table above refers to the maximum deflection of the appropriate set. When smaller dimensions are measured, the error is smaller and corresponds to the error value of the smaller sets.

## 0894 Individual extensions



✕	⊘	Length mm	Tube dia. mm	Order no.	List price EUR
		50	17	0894 804	160.00
		100	17	0894 806	182.00
		200	17	0894 810	197.00
		400	17	0894 820	217.00
		800	17	0894 834	247.00
		500	32	0894 854	811.00
		1000	32	0894 872	842.00



## 0940 DIGI-MET® 2 point internal micrometers with extensions



### Model

- Non-rotating spindle
- LCD display 6 mm
- Carbide measuring faces Ø 8 mm
- Selectable resolution 0.01 mm / 0.001 mm ; 0.0005 inch / 0.00005 inch
- Ratchet stop
- For precise measuring of inner dimensions up to 5000 mm

### Functions

- ON / OFF
- Set to zero at any point
- mm / inch switching
- Data output Opto RS 232
- MIN / MAX
- Hold
- TOL (tolerance value input)
- PRESET-Function (setting a numerical value)

### Delivery

- Wooden case



**NEW**

0940 816



»	¼	Measuring range mm	Pitch mm	Extensions	Order no.	List price EUR
		150 - 175	1	Basic unit	0940 816	835.00
		150 - 350	1	25 / 50 / 100	0940 823	1195.00
		150 - 550	1	25 / 50 / 100 / 200	0940 829	1360.00
		150 - 950	1	25 / 50 / 100 / 200 / 400	0940 833	1530.00
		150 - 1550	1	25 / 50 / 100 / 200 / 200 / 400 / 400	0940 839	1750.00



0996705

0996701

0997770

### Accessories

	Order no.	List price EUR
Battery, 3V-Lithium, CR 2032	0220 704	3.70
Data cable opto to RS232	0996 701	74.00
Data cable opto to USB	0996 705	141.00
USB-keyboard interface cable	0997 770	241.00

## 0940 Individual extension



M 12x1



»	¼	Length mm	Tube dia. mm	Order no.	List price EUR
		25	17	0940 891	129.00
		50	17	0940 892	145.00
		100	17	0940 893	179.00
		200	17	0940 894	219.00
		400	17	0940 895	295.00
		1000	32	0940 896	895.00



## 1921 3 point internal micrometers



**DIN  
863-4**



1921 512



1921 534

### Model

- DIN 863-4
- Reading: 0.001 mm\*
- Reading: 0.005 mm
- Reading parts are satin chrome finished
- Pitch 0.5 mm
- Carbide tipped measuring pins from measuring range 12 mm

### Delivery

- Plastic case
- Setting ring inclusive
- Calibration certificate for ring and device



**Inclusive!**

✂	📏	Measuring range mm	Measuring depth mm	Thimble dia. mm	Error limit µm	Order no.	List price EUR
▪		6 - 8	58	16	4	1921 510*	384.00
▪		8 - 10	58	16	4	1921 512*	384.00
▪		10 - 12	58	16	4	1921 514*	384.00
▪		12 - 16	64	16	4	1921 516*	384.00
▪		16 - 20	64	16	4	1921 518*	405.00
▪		20 - 25	68	25	4	1921 520	416.00
▪		25 - 30	68	25	4	1921 522	421.00
▪		30 - 40	76	25	4	1921 524	473.00
▪		40 - 50	76	25	4	1921 526	473.00
▪		50 - 60	79	25	5	1921 528	545.00
▪		60 - 70	79	25	5	1921 530	561.00
▪		70 - 85	97	25	5	1921 532	577.00
▪		85 - 100	97	25	5	1921 534	592.00
▪		100 - 125	132	25	6	1921 536	831.00
▪		125 - 150	132	25	6	1921 538	982.00
▪		150 - 175	132	25	7	1921 540	1034.00
▪		175 - 200	132	25	7	1921 542	1091.00





## 1920 Set of 3 point internal micrometers



**DIN  
863-4**



### Model

- DIN 863-4
- Reading: 0.001 mm\*
- Reading: 0.005 mm
- Reading parts are satin chrome finished
- Pitch 0.5 mm
- Carbide tipped measuring pins from measuring range 12 mm
- Ratchet stop
- From measuring range 12 mm for through and blind holes

### Delivery

- Plastic case
- Setting ring inclusive
- Calibration certificate for ring and device

2

⌘	⚙	Measuring range mm	Thimble dia. mm	Number of devices	Order no.	List price EUR
▪		6 - 12	16	3	1920 574	1081.00
▪		12 - 20	16	2	1920 576	758.00
▪		20 - 50	25	4	1920 578	1870.00
▪		50 - 100	25	4	1920 580	2234.00

## 1920 Measuring depth extensions for 3 point internal micrometers



### Model

- Suitable for devices 1920, 1921, 1923 and 1924



⌘	⚙	Measuring range mm	Length mm	Order no.	List price EUR
		6 - 12	75	1920 910	88.00
		12 - 20	75	1920 914	94.00
		20 - 30	150	1920 920	99.00
		30 - 200	150	1920 924	119.00



## 1923 DIGI-MET® 3 point internal micrometers



**NEW**

### Model

- DIN 863-4
- Reading: 0.001 mm / .00005 inch
- Protection class IP52
- LCD display 8.5 mm
- Ratchet stop
- For through holes
- From measuring range 12 mm for through and blind holes
- From measuring range 12 mm with carbide tipped measuring faces

### Functions

- ON / OFF
- Set to zero at any point
- mm / inch switching
- ABS (display can be set to zero without losing the Preset value)
- **Quick-Lock** (key lock)
- PRESET-Function (setting a numerical value)
- Variable data output RS 232 + Digimatic + USB

### Delivery

- Plastic case
- Incl. setting ring
- Certificate for setting ring and micrometer



**Inclusive!**

✕	☒	Measuring range mm	Measuring depth mm	Error limit µm	Order no.	List price EUR
▪		6 - 8	58	4	1923 510	1055.00
▪		8 - 10	58	4	1923 512	1055.00
▪		10 - 12	58	4	1923 514	1065.00
▪		12 - 16	64	4	1923 516	1065.00
▪		16 - 20	64	4	1923 518	1110.00
▪		20 - 25	68	4	1923 520	1130.00
▪		25 - 30	68	4	1923 522	1140.00
▪		30 - 40	76	4	1923 524	1190.00
▪		40 - 50	76	4	1923 526	1195.00
▪		50 - 60	79	5	1923 528	1285.00
▪		60 - 70	79	5	1923 530	1315.00
▪		70 - 85	97	5	1923 532	1345.00
▪		85 - 100	97	5	1923 534	1395.00
▪		100 - 125	132	6	1923 536	1695.00
▪		125 - 150	132	6	1923 538	1895.00
▪		150 - 175	132	7	1923 540	2040.00
▪		175 - 200	132	7	1923 542	2215.00



1998720

1998501

1997501

### Accessories

	Order no.	List price EUR
Battery, 3V-Lithium, CR 2032	0220 704	3.70
Data cable DATA VARIABLE to RS232	1997 501	48.00
Data cable DATA VARIABLE to digimatic	1998 501	61.00
Data cable DATA VARIABLE to USB	1998 720	69.00



## 1923 DIGI-MET® Set of 3 point internal micrometers



### Delivery

- Plastic case
- Incl. setting ring
- Certificate for setting ring and micrometer



Measuring range mm	Error limit µm	Number of devices	Order no.	List price EUR
6 - 12	4	3	1923 574	1700.00
12 - 20	4	2	1923 576	1500.00
20 - 50	4	4	1923 578	2200.00
50 - 100	5	4	1923 580	2700.00



1998720



1998501



1997501

### Accessories

	Order no.	List price EUR
Battery, 3V-Lithium, CR 2032	0220 704	3.70
Data cable DATA VARIABLE to RS232	1997 501	48.00
Data cable DATA VARIABLE to digimatic	1998 501	61.00
Data cable DATA VARIABLE to USB	1998 720	69.00

## 1923 DIGI-MET® Basic unit for 3 point internal micrometers



### Model

- Reading: 0.001 mm / .00005 inch
- Protection class IP52
- LCD display 8,5 mm
- Ratchet stop
- Mounting thread for changing of measuring heads

### Functions

- ON / OFF
- Set to zero at any point
- mm / inch switching
- ABS (display can be set to zero without losing the Preset value)
- Quick-Lock (key lock)
- PRESET-Function (setting a numerical value)
- Variable data output RS 232 + Digimatic + USB

Measuring range mm	Order no.	List price EUR
6 - 20	1923 100	765.00
20 - 100	1923 200	765.00
100 - 200	1923 300	765.00



## 1924 DIGI-MET® 3 point internal measuring pistols



**NEW**

### Model

- For through holes
- Mounting thread for changing of measuring heads
- From measuring range 12 mm for through and blind holes
- From measuring range 12 mm with carbide tipped measuring faces
- Digital indicator recommended as display device

### Delivery

- Plastic case
- Incl. setting ring
- Without display device



**Inclusive!**

⌘	⚙	Measuring range mm	Measuring depth mm	Order no.	List price EUR
▪		6 - 8	58	1924 510	785.00
▪		8 - 10	58	1924 512	785.00
▪		10 - 12	58	1924 514	795.00
▪		12 - 16	64	1924 516	805.00
▪		16 - 20	64	1924 518	835.00
▪		20 - 25	68	1924 520	835.00
▪		25 - 30	68	1924 522	865.00
▪		30 - 40	76	1924 524	910.00
▪		40 - 50	76	1924 526	915.00
▪		50 - 60	79	1924 528	995.00
▪		60 - 70	79	1924 530	1035.00
▪		70 - 85	97	1924 532	1070.00
▪		85 - 100	97	1924 534	1120.00
▪		100 - 125	132	1924 536	1380.00
▪		125 - 150	132	1924 538	1590.00
▪		150 - 175	132	1924 540	1700.00
▪		175 - 200	132	1924 542	1900.00



1726506



172650660

### Accessories

DIGI-MET® Indicators  
DIGI-MET® Indicators with integrated wireless

Order no.

1726 506  
172650 660

List price  
EUR

365.00  
425.00



## 1924 DIGI-MET® Set of 3 point internal measuring pistols



### Model

- For through holes
- From measuring range 12 mm for through and blind holes
- From measuring range 12 mm with carbide tipped measuring faces
- Digital indicator recommended as display device

### Delivery

- Plastic case
- Incl. setting ring
- Without display device

▶▶	📏	Measuring range mm	Number of devices	Order no.	List price EUR
▪		6 - 12	3	1924 574	1400.00
▪		12 - 20	2	1924 576	1200.00
▪		20 - 50	4	1924 578	2000.00
▪		50 - 100	4	1924 580	2600.00

2

## 1924 DIGI-MET® Basic unit for 3 point internal measuring pistols



### Model

- Mounting thread for changing of measuring heads
- Support for indicators with shaft Ø 8 mm
- Measuring range 6-100 mm incl. adapter for 6-20 mm

### Delivery

- Plastic case

▶▶	📏	Measuring range mm	Order no.	List price EUR
		6 - 100	1924 100	480.00
		20 - 100	1924 200	480.00
		100 - 200	1924 300	560.00



## 1922 Individual measuring heads for 1923 / 1924



1922 512



1922 534

### Model

- From measuring range 12 mm with carbide tipped measuring faces
- From measuring range 12 mm for through and blind holes

▶	⚙	Measuring range mm	Order no.	List price EUR
		6 - 8	1922 510	290.00
		8 - 10	1922 512	290.00
		10 - 12	1922 514	295.00
		12 - 16	1922 516	295.00
		16 - 20	1922 518	305.00
		20 - 25	1922 520	315.00
		25 - 30	1922 522	325.00
		30 - 40	1922 524	365.00
		40 - 50	1922 526	365.00
		50 - 60	1922 528	435.00
		60 - 70	1922 530	445.00
		70 - 85	1922 532	460.00
		85 - 100	1922 534	475.00
		100 - 125	1922 536	695.00
		125 - 150	1922 538	845.00
		150 - 175	1922 540	915.00
		175 - 200	1922 542	945.00

## 1920 Measuring depth extensions for 3 point internal micrometers



### Model

- Suitable for devices 1920, 1921, 1923 and 1924

▶	⚙	Measuring range mm	Length mm	Order no.	List price EUR
		6 - 12	75	1920 910	88.00
		12 - 20	75	1920 914	94.00
		20 - 30	150	1920 920	99.00
		30 - 200	150	1920 924	119.00



## 0882 Depth micrometers



DIN  
863-2

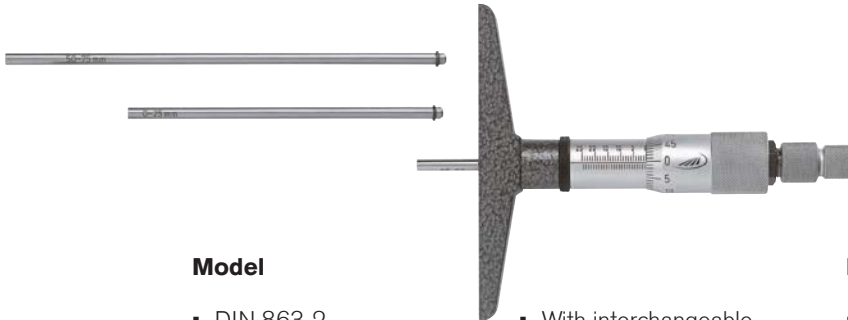

### Model

- DIN 863-2
- Reading: 0.01 mm
- Reading parts are satin chrome finished
- Locking ring
- Friction coupling

### Delivery

- Wooden case

- With interchangeable steel measuring inserts dia. 4 mm
- Hardened measuring faces

»	¼	Measuring range mm	Bridge length mm	Pitch mm	Thimble dia. mm	Error limit mm	Order no.	List price EUR
<b>Measuring faces dia. 0.8. length 8.5 mm</b>								
		0 - 50	50	0.5	20	0.004	0882 300	263.00
		0 - 75	50	0.5	20	0.005	0882 301	286.00
		0 - 100	100	0.5	20	0.005	0882 303	314.00
		0 - 150	100	0.5	20	0.006	0882 304	368.00
		0 - 300	100	0.5	20	0.009	0882 306	592.00

## 0886 Micrometer heads



DIN  
863-2



0886 503



0886 507

### Model

- DIN 863-2
- Reading: 0.01 mm
- Reading parts are satin chrome finished
- Carbide measuring faces

### Delivery

- Plastic case

»	¼	Measuring range mm	Spindle dia. mm	Thimble dia. mm	Error limit mm	Description	Order no.	List price EUR
		0 - 6.5	3.5	9.5	0.003	without ratchet stop	0886 503	23.40
		0 - 13	6.5	13.5	0.003	without ratchet stop	0886 505	27.00
		0 - 25	6.5	18	0.003	with ratchet stop	0886 507	23.40
		0 - 25	8	18	0.003	with ratchet stop, non-rotating spindle	0886 513	41.60